

# Engine Electrical System (1.1 SOHC)

GENERAL.....	EE - 2
IGNITION SYSTEM .....	EE - 11
CHARGING SYSTEM.....	EE - 16
STARTING SYSTEM.....	EE - 30

# GENERAL

## SPECIFICATION

### IGNITION SYSTEM

Items		Specification
Ignition coil	Primary resistance	0.87 10%( $\Omega$ )
	Secondary resistance	13.0 15% (k $\Omega$ )
S T A R Spark Plugs	NGK	BKR5ES-11
	CHAMPION	RC10YC4
	Gap	1.0 ~ 1.1 mm (0.0394 ~ 0.0433 in.)

### STARTING SYSTEM

Items		Specification	
Starter	Rated Voltage	12V, 0.9kW	
	No. of pinion teeth	8	
	No-load characteristics	Voltage	11.5V
		Ampere	60A
		Speed	5,500 rpm
	Commutator diameter	Standard	33.0 mm (1.2992 in.)
		Limit	32.4 mm (1.2756 in.)
	Under cut depth	Standard	0.5 mm (0.0197 in.)
		Limit	0.2 mm (0.0079 in.)

## CHARGING SYSTEM

Items		Specification
Alternator	Type	Battery voltage sensing
	Rate voltage	13.5V, 70A
	Speed in use	1,000 ~ 18,000 rpm
	Voltage regulator	Electronic built-in type
	Regulator setting voltage	14.7 ± 0.3V
	Temperature compensation	-7 ± 3mV / °C
Battery	Type	MF 40AH
	Cold cranking amperage [at -18°C (-0.4°F)]	354A
	Reserve capacity	55 min
	Specific gravity [at 20°C (68°F)]	1.280 ± 0.01

**CAUTION**

- **COLD CRANKING AMPERAGE** is the amperage a battery can deliver for 30 seconds and maintain a terminal voltage of 7.2V or greater at a specified temperature.
- **RESERVE CAPACITY RATING** is amount of time a battery can deliver 25A and maintain a minimum terminal voltage of 10.5V at 26.7°C (80.1 °F).

## TROUBLE SHOOTING

### IGNITION SYSTEM

Symptom	Suspect area	Remedy
Engine will not start or is hard to start (Crank OK)	Ignition lock switch Ignition coil Spark plugs Ignition wiring disconnected or broken Spark plugs cable	Inspect ignition lock switch, or replace as required Inspect ignition coil, or replace as required Inspect spark plugs, or replace as required Repair wiring, or replace as required Inspect cable, or replace as required
Rough idle or stalls	Ignition wiring Ignition coil Spark plugs cable	Repair wiring, or replace as required Inspect ignition coil, or replace as required Inspect cable, or replace as required
Engine hesitates/poor acceleration	Spark plugs and spark plug cables Ignition wiring	Inspect spark plugs / cable, or replace as required Repair wiring, or replace as required
Poor mileage	Spark plugs and spark plug cables	Inspect spark plugs / cable, or replace as required

### CHARGING SYSTEM

Symptom	Suspect area	Remedy
Charging warning indicator does not light with ignition switch "ON" and engine off.	Fuse blown Light burned out Wiring connection loose Electronic voltage regulator	Check fuses Replace light Tighten loose connection Replace voltage regulator
Charging warning indicator does not go out with engine running. (Battery requires frequent recharging)	Drive belt loose or worn Battery cable loose, corroded or worn Electronic voltage regulator or alternator Wiring	Adjust belt tension or replace belt Inspect cable connection, repair or replace cable Replace voltage regulator or alternator Repair or replace wiring
Overcharge	Electronic voltage regulator Voltage sensing wire	Replace voltage regulator Repair or replace wiring
Discharge	Drive belt loose or worn Wiring connection loose or short circuit Electronic voltage regulator or alternator Poor grounding Worn battery	Adjust belt tension or replace belt Inspect wiring connection, repair or replace wiring Replace voltage regulator or alternator Inspect ground or repair Replace battery

**STARTING SYSTEM**

<b>Symptom</b>	<b>Suspect area</b>	<b>Remedy</b>
Engine will not crank	Battery charge low Battery cables loose, corroded or worn out Transaxle range switch (Vehicle with automatic transaxle only) Fuse blown Starter motor faulty Ignition switch faulty	Charge or replace battery Repair or replace cables  Refer to TR group-automatic transaxle  Replace fuse Replace Replace
Engine cranks slowly	Battery charge low Battery cables loose, corroded or worn out Starter motor faulty	Charge or replace battery Repair or replace cables  Replace
Starter keeps running	Starter motor Ignition switch	Replace Replace
Starter spins but engine will not crank	Short in wiring Pinion gear teeth broken or starter motor Ring gear teeth broken	Repair wiring Replace Replace fly wheel or torque converter

**BATTERY TEST PROCEDURE**

1. Connect the tester to the battery.  
 Red clamp to battery positive (+) terminal.  
 Black clamp to battery negative (-) terminal.

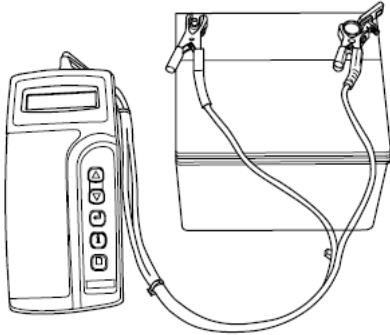

**CAUTION**

**Connect clamps securely. If "CHECK CONNECTION" message is displayed on the screen, reconnect clamps securely.**

2. The tester will ask if the battery is connected "IN A VEHICLE" or "OUT OF A VEHICLE". Make your selection by pressing the arrow buttons; then press ENTER.

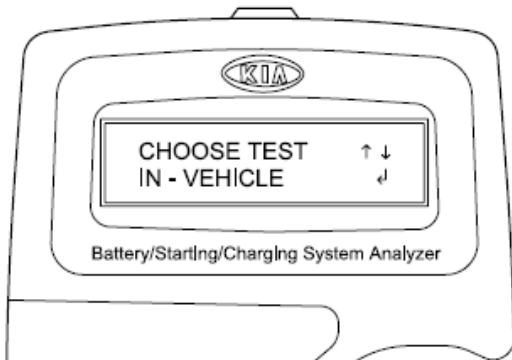

3. Choose either CCA or CCP and press the ENTER button.

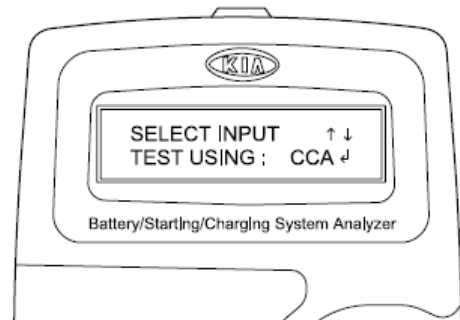

**NOTE**

- CCA : Cold cranking amps, is an SAE specification for cranking batteries at -0.4 F (-18 C).
- CCP : Cold cranking amps, is an SAE specification for Korean manufacturer's for cranking batteries at -0.4 F (-18 C).

4. Set the CCA value displayed on the screen to the CCA value marked on the battery label by pressing up and down buttons and press ENTER.

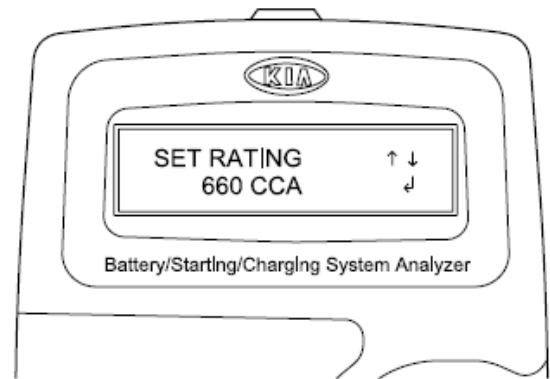

**NOTE**

*The battery ratings(CCA) displayed on the tester must be identical to the ratings marked on battery label.*

5. The tester (Micro570) displays battery test results including voltage and battery ratings. A relevant action must be given according to the test results by referring to the battery test results as shown in the table below.

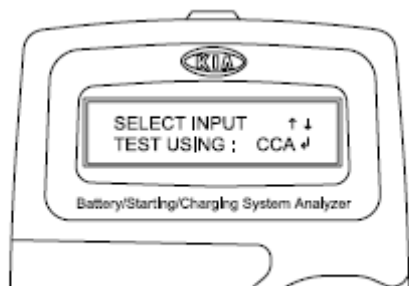

**NOTE**

*The battery ratings (CCA) displayed on the tester must be identical to the ratings marked on battery label.*

6. To conduct starter test, continuously, press ENTER.

**BATTERY TEST RESULTS**

RESULT ON PRINTER	REMEDY
Good battery	No action is required
Good recharge	Battery is in a good state Recharge the battery and use
Charge & Retest	Battery is not charged properly ⇒ Charge and test the battery again (Failure to charge the battery fully may read incorrect measurement value)
Replace battery	⇒ Replace battery and recheck the charging system. (Improper connection between battery and vehicle cables may cause "REPLACE BATTERY", retest the battery after removing cables and connecting the tester to the battery terminal directly prior to replacing the battery)
Bad cell-replace	⇒ Charge and retest the battery. And then, test results may cause "REPLACE BATTERY", replace battery and recheck the charging system

**STARTER TEST PROCEDURE**

1. After the battery test, press ENTER immediately for the starter test.

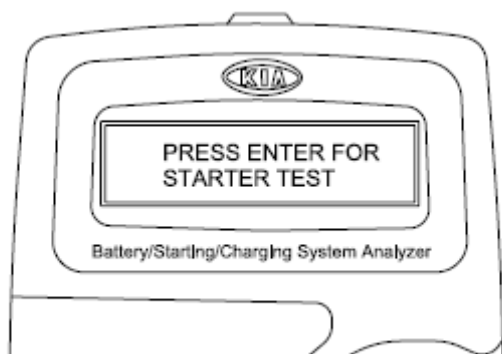

2. After pressing ENTER key, start the engine.

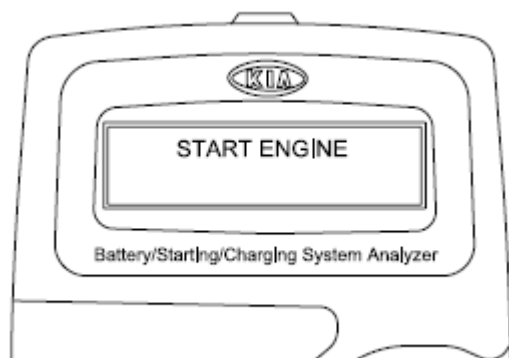

3. Cranking voltage and starter test results will be displayed on the screen.

Take a relevant action according to the test results by referring to the starter test results as given below.

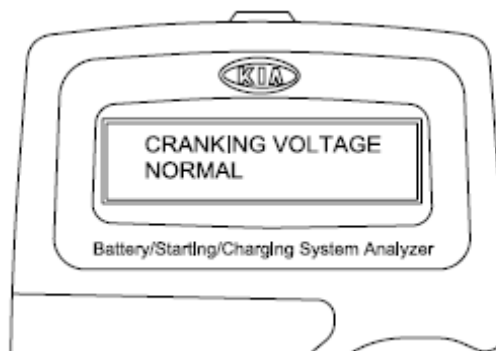

4. To continue charging system test, press ENTER.



**STARTER TEST RESULTS**

RESULT ON PRINTER	REMEDY
Cranking voltage normal	System shows a normal starter draw
Cranking voltage low	Cranking voltage is lower than normal level ⇒ Check starter
Charge battery	The state of battery charge is too low to test ⇒ Charge the battery and retest
Replace battery	⇒ Replace battery ⇒ If the vehicle is not started though the battery condition of "Good and fully charged" is displayed. ⇒ Check wiring for open circuit, battery cable connection, starter and repair or replace as necessary. ⇒ If the engine does crank, check fuel system.

**NOTE**

*When testing the vehicle with old diesel engines, the test result will not be favorable if the glow plug is not heated. Conduct the test after warming up the engine for 5 minutes.*

2. If ENTER button is pressed, the tester displays the actual voltage of alternator.  
Press ENTER to test the charging system.

**CHARGING SYSTEM TEST PROCEDURE**

1. Press ENTER to begin charging system test.

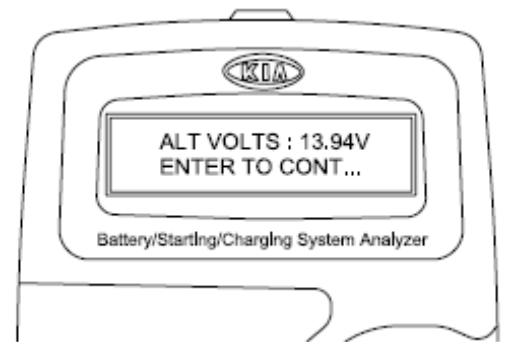
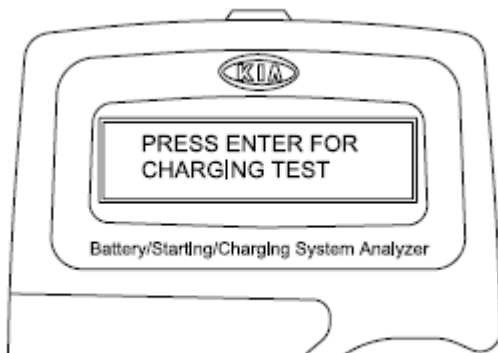

3. Turn off all electrical load and rev engine for 5 seconds with pressing the accelerator pedal.

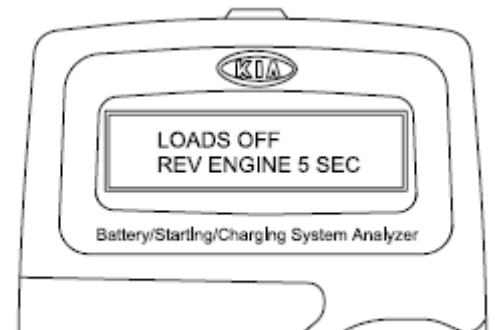

4. Press ENTER.

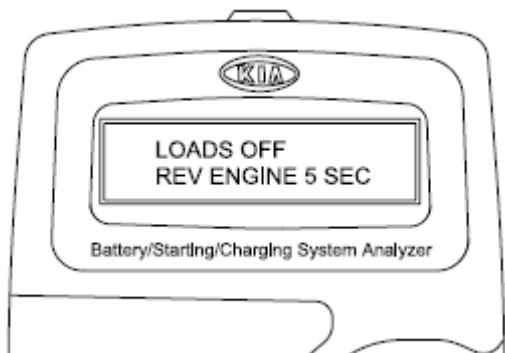

6. Take a relevant action according to the test results by referring to the table below after shutting off the engine and disconnect the tester clamps from the battery.

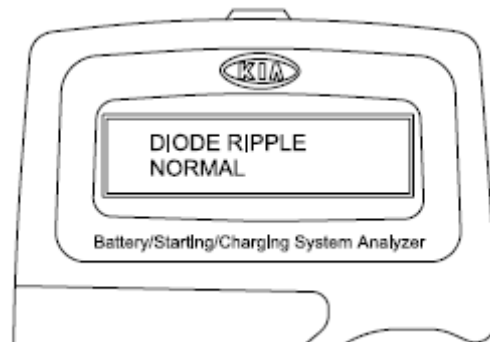

5. The MICRO 570 analyzer charging system output at idle for comparison to other readings.

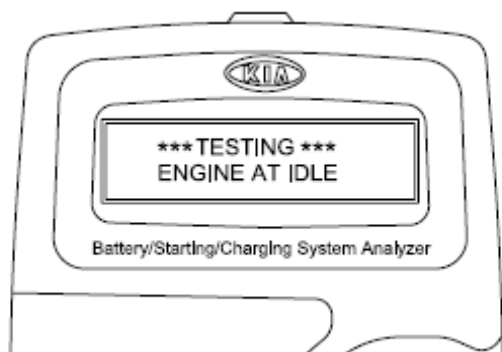

**CHARGING SYSTEM TEST RESULTS**

RESULT ON PRINTER	REMEDY
Charging system normal / Diode ripple normal	Charging system is normal
No charging voltage	Alternator does not supply charging current to battery ⇒ Check belts, connection between alternator and battery Replace belts or cable or alternator as necessary
Low charging voltage	Alternator does not supply charging current to battery and electrical load to system fully ⇒ Check belts and alternator and replace as necessary
High charging voltage	The voltage from alternator to battery is higher than normal limit during voltage regulating. ⇒ Check connection and ground and replace regulator as necessary ⇒ Check electrolyte level in the battery
Excess ripple detected	One or more diodes in the alternator is not functioning properly ⇒ Check alternator mounting and belts and replace as necessary

# IGNITION SYSTEM

## DESCRIPTION

Ignition timing is controlled by the electronic control ignition timing system. The standard reference ignition timing data for the engine operating conditions are pre-programmed in the memory of the ECM (Engine Control Module).

The engine operating conditions (speed, load, warm-up condition, etc.) are detected by the various sensors. Based on these sensor signals and the ignition timing data, signals to interrupt the primary current are sent to the ECM. The ignition coil is activated, and timing is controlled.

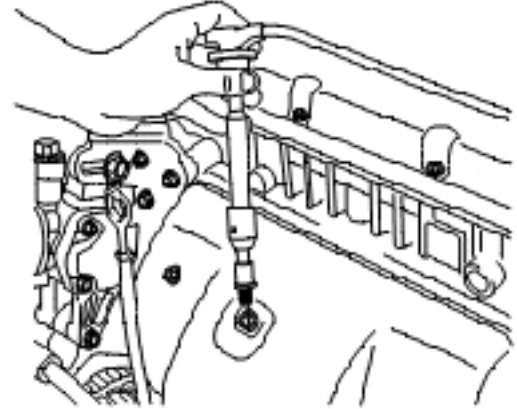

## ON-VEHICLE INSPECTION

### SPARK TEST

1. Disconnect the spark plug cable(A) from the spark plug.

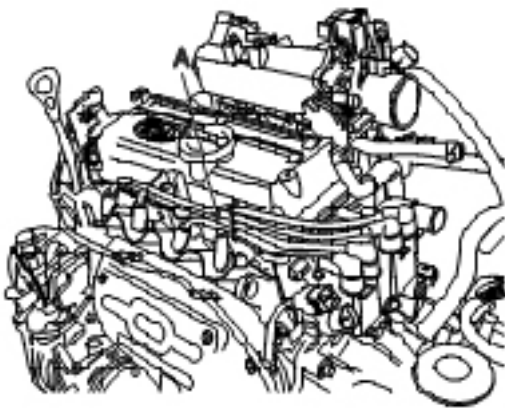

2. Using a spark plug socket, remove the spark plug.

3. Install the spark plug to the spark plug cable.

4. Ground the spark plug to the engine.

5. Check if spark occurs while engine is being cranked.

### NOTE

*To prevent fuel being injected from injectors while the engine is being cranked, remove the fuel pump relay (A) from the fuse box.*

*Crank the engine for no more than 5 ~ 10 seconds.*

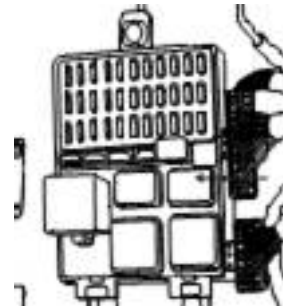

6. Inspect all the spark plugs.

7. Using a spark plug socket, install the spark plugs.

8. Install the spark plug cables.

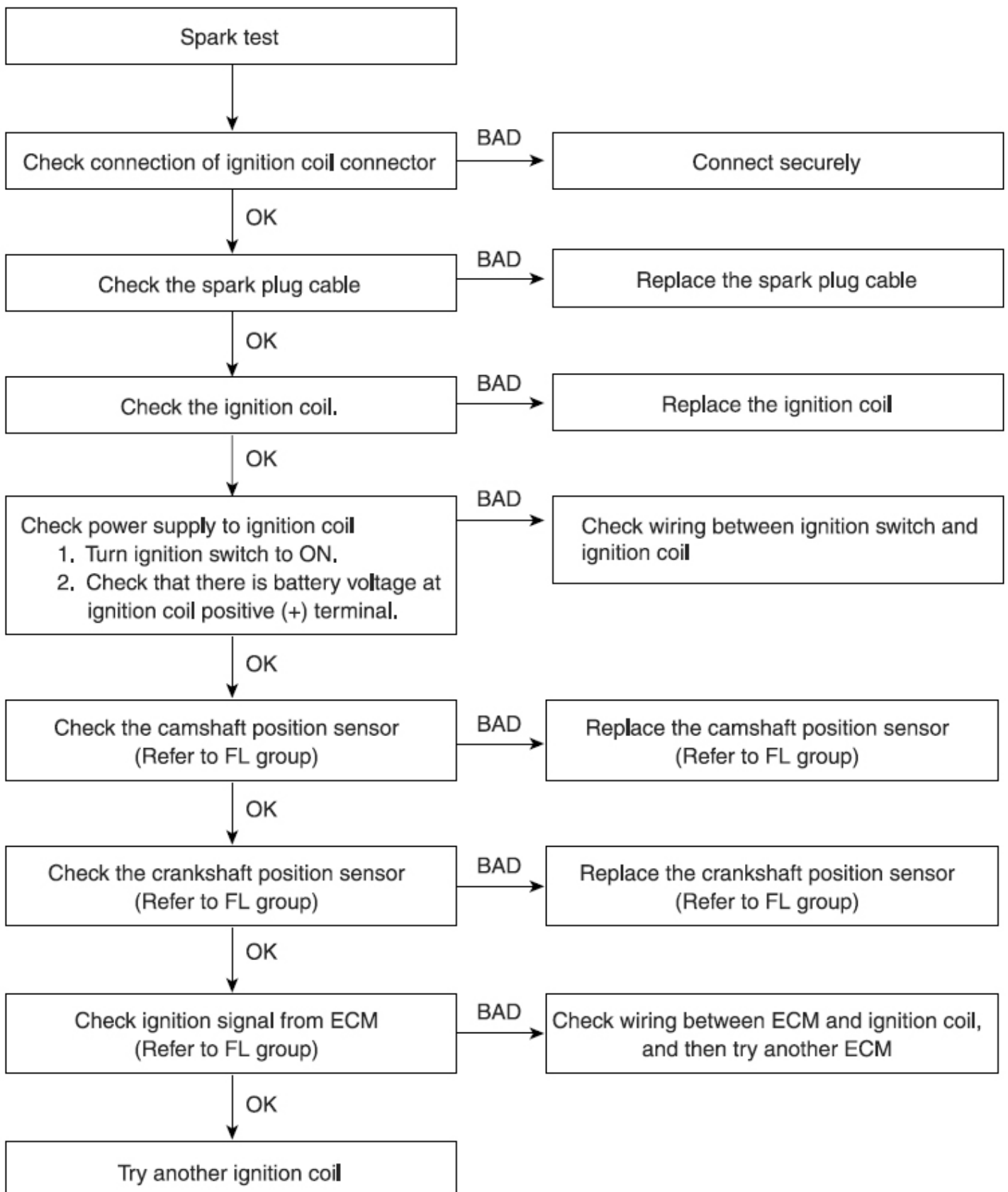

**INSPECT SPARK PLUG**

1.Remove the spark plug cables (A).

**NOTE**

*When removing the spark plug cable, pull on the sparkplug cable boot (not the cable), as it may be damaged.*

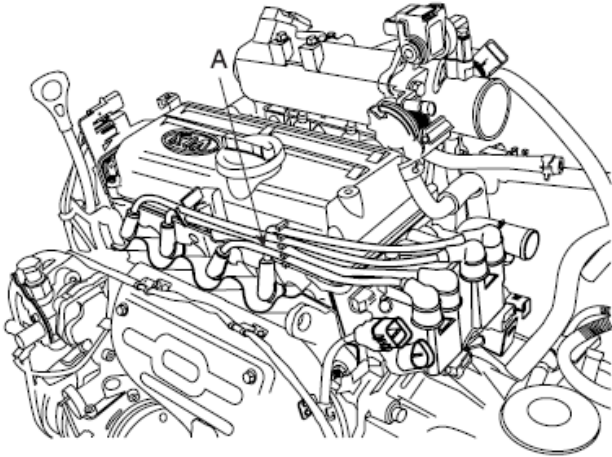

2.Using a spark plug socket, remove the spark plug.

**CAUTION**

***Be careful that no contaminates enter through the spark plug holes.***

3.Inspect the electrodes (A) and ceramic insulator (B).

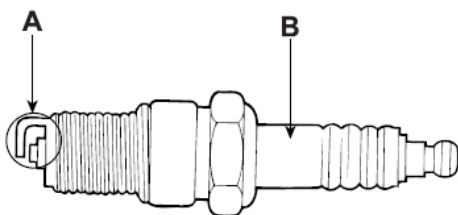

**INSPECTION OF ELECTRODES**

Condition	Dark deposits	White deposits
<b>Description</b>	- Fuel mixture too rich - Low air intake	- Fuel mixture too lean - Advanced ignition timing - Insufficient plug tightening torque

4.Check the electrode gap (A).

**Standard (New): 1.0 ~ 1.1 mm (0.0394 ~ 0.0433 in.)**

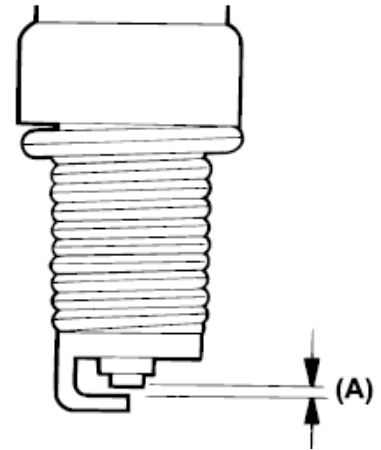

### INSPECT SPARK PLUG CABLE

- Carefully remove the spark plug cable by pulling on the rubber boots (A).  
Check the condition of the spark plug cable terminals (B), if any terminal has surface corrosion, clean it off, and if it broken or distorted, replace the spark plug cable.

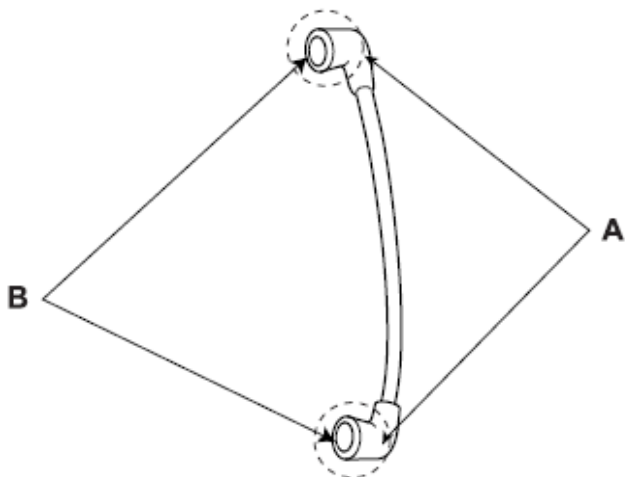

- Connect the ohmmeter probes and measure resistance.

**Resistance:  $5.6k \Omega / m \pm 20 \%$**

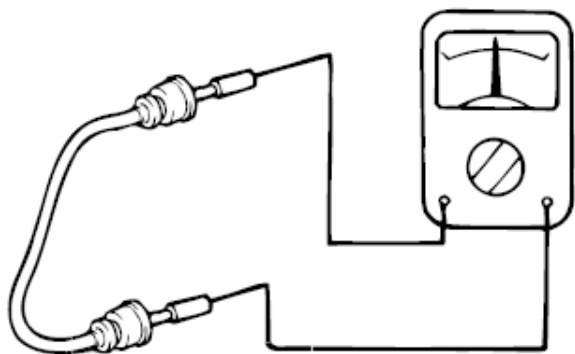

- Resistance should not be higher than  $10 \text{ } \Omega / m$ .  
If resistance is higher, replace the cable.

### INSPECT IGNITION COIL

- Measure the primary coil resistance between terminals 1, 2 and 1, 3

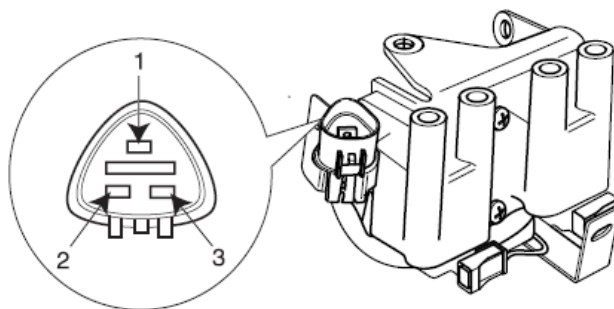

**Standard value:  $0.58 \Omega \pm 10\%$**

- Measure the secondary coil resistance between the high-voltage terminals for the No.1 and No. 4 cylinders, and between the high voltage terminals for the No. 2 and No. 3 cylinders.

**Standard value:  $8.8 \Omega / m \pm 15\%$**

#### CAUTION

**Be sure, when measuring the resistance of the secondary coil, to disconnect the connector of the ignition coil.**

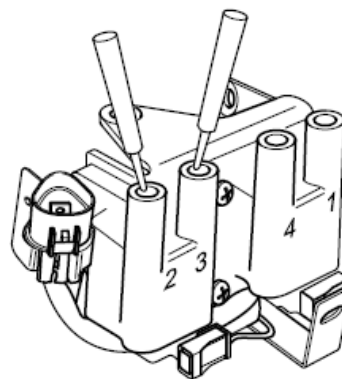

## REPLACEMENT

### IGNITION COIL

1. Disconnect the spark plug cables (A) and ignition coil connector (B).

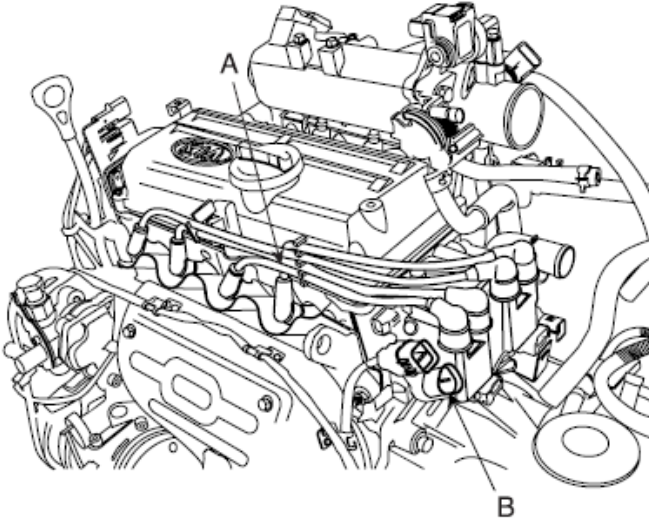

2. Remove the ignition coil (A).

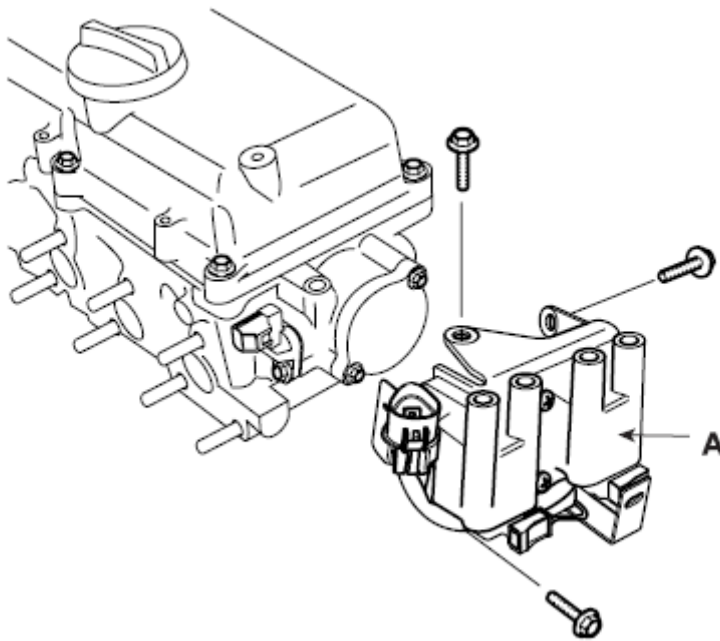

3. Installation is the reverse of removal.

## CHARGING SYSTEM

### DESCRIPTION

The charging system consists a battery, an alternator with a built-in regulator, and the charging indicator light and wire.

The Alternator has built-in diodes, each rectifying AC current to DC current.

Therefore, DC current is present at the alternator "B" terminal. Additionally, the alternator and charging voltage is regulated by the battery voltage detection system.

The alternators is regulated by the battery voltage detection system. The main components of the alternator are the rotor, stator, rectifier, capacitor, brushes, bearings and V-ribbed belt pulley. The brush holder contains a built-in electronic voltage regulator.

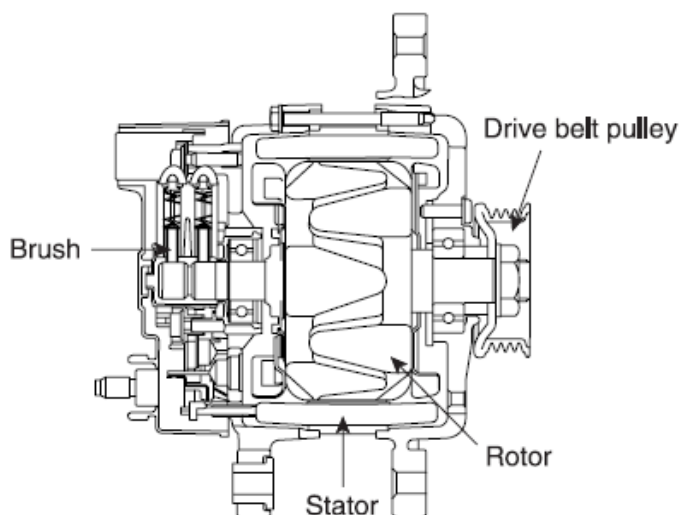

### ON-VEHICLE INSPECTION

#### CAUTION

- **Check that the battery cables are connected to the correct terminals.**
- **Disconnect the battery cables when the battery is given a quick charge.**
- **Never disconnect the battery while the engine is running.**

#### CHECK BATTERY VOLTAGE

1. If 20 minutes have not passed since the engine was stopped, turn the ignition switch ON and turn on the electrical system (headlamp, blower motor, rear de fogger etc.) for 60 seconds to remove the surface charge.
2. Turn the ignition switch OFF and turn off the electrical systems.
3. Measure the battery voltage between the negative (-) and positive (+) terminals of the battery.

**Standard voltage: 12.5 ~ 12.9V at 20°C(68°F)**

If the voltage is less than specification, charge the battery.

#### CHECK THE BATTERY TERMINALS AND FUSES

1. Check that the battery terminals are not loose or corroded.
2. Check the fuses for continuity.



**INSPECT DRIVE BELT**

1. Visually check the belt for excessive wear, frayed cords etc.  
If any defect has been found, replace the drive belt.

**NOTE**

Cracks on the rib side of a belt are considered acceptable. If the belt has chunks missing from the ribs, it should be replaced.

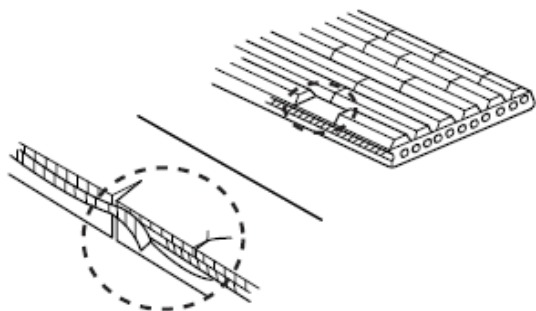

2. Measure the drive belt tension and adjust it.  
Apply a force of 98N (10kg, 22lb), and measure the deflection between the alternator and water pump pulley.

**DEFLECTION**

New belt	8.5 ~ 9.5 mm (0.3346 ~ 0.3740 in.)
Used belt	9.5 ~ 11.0 mm (0.3740 ~ 0.4331 in.)

If the belt tension is not as specified, adjust it.

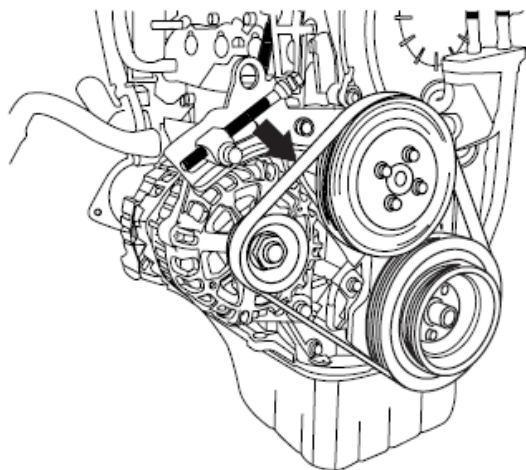

**NOTE**

- "New belt" refers to a belt which has been used less than 5 minutes on a running engine.
- "Used belt" refers to a belt which has been used on a running engine for 5 minutes or more.
- After installing a belt, check that it fits properly in the ribbed grooves.
- Check with your hand to confirm that the belt has not slipped out of the groove on the bottom of the pulley.
- After installing a new belt, run the engine for about 5 minutes and recheck the belt tension.

**VISUALLY CHECK ALTERNATOR WIRING AND LISTEN FOR ABNORMAL NOISES**

1. Check that the wiring is in good condition.
2. Check that there is no abnormal noise from the alternator while the engine is running.

**CHECK DISCHARGE WARNING LIGHT CIRCUIT**

1. Warm up the engine, and then turn it off.
2. Turn off all accessories.
3. Turn the ignition switch "ON". Check that the discharge warning light is lit.
4. Start the engine. Check that the light is lit.  
If the light does not go off as specified, troubleshoot the discharge light circuit.

## INSPECT CHARGING SYSTEM

### VOLTAGE DROP TEST OF ALTERNATOR OUTPUT WIRE

This test determines whether or not the wiring between the alternator "B" terminal and the battery (+) terminal is good by the voltage drop method.

#### PREPARATION

1. Turn the ignition switch to "OFF".
2. Disconnect the output wire from the alternator "B" terminal. Connect the (+) lead wire of ammeter to the "B" terminal of alternator and the (-) lead wire of ammeter to the output wire. Connect the (+) lead wire of voltmeter to the "B" terminal of alternator and the (-) lead wire of voltmeter to the (+) terminal of battery.

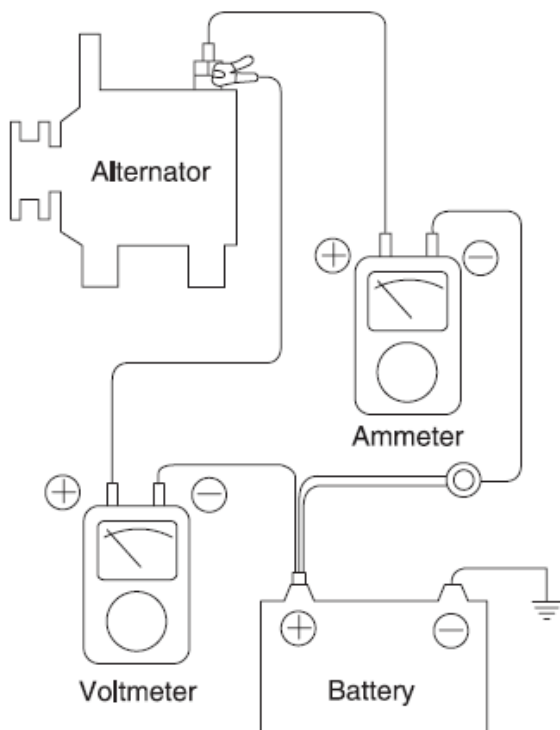

#### TEST

1. Start the engine.
2. Turn on the headlamps and blower motor, and set the engine speed until the ammeter indicates 20A. And then, read the voltmeter at this time.

#### RESULT

1. The voltmeter may indicate the standard value.

**Standard value: 0.2V max**

2. If the value of the voltmeter is higher than expected (above 0.2V max.), poor wiring is suspected. In this case check the wiring from the alternator "B" terminal to the battery (+) terminal. Check for loose connections, color change due to an over-heated harness, etc. Correct them before testing again.
3. Upon completion of the test, set the engine speed at idle. Turn off the headlamps, blower motor and the ignition switch.

## OUTPUT CURRENT TEST

This test determines whether or not the alternator gives an output current that is equivalent to the normal output.

### PREPARATION

1. Prior to the test, check the following items and correct as necessary.  
Check the battery installed in the vehicle to ensure that it is good condition. The battery checking method is described in the section "Battery".  
The battery that is used to test the output current should be one that has been partially discharged. With a fully charged battery, the test may not be conducted correctly due to an insufficient load.  
Check the tension of the alternator drive belt. The belt tension check method is described in the section "Inspect drive belt".
2. Turn off the ignition switch.
3. Disconnect the battery ground cable.
4. Disconnect the alternator output wire from the alternator "B" terminal.
5. Connect a DC ammeter (0 to 150A) in series between the "B" terminal and the disconnected output wire. Be sure to connect the (-) lead wire of the ammeter to the disconnected output wire.

### NOTE

*Tighten each connection securely, as a heavy current will flow. Do not rely on clips.*

6. Connect a voltmeter (0 to 20V) between the "B" terminal and ground. Connect the (+) lead wire to the alternator "B" terminal and (-) lead wire to a good ground.
7. Attach an engine tachometer and connect the battery ground cable.
8. Leave the engine hood open.

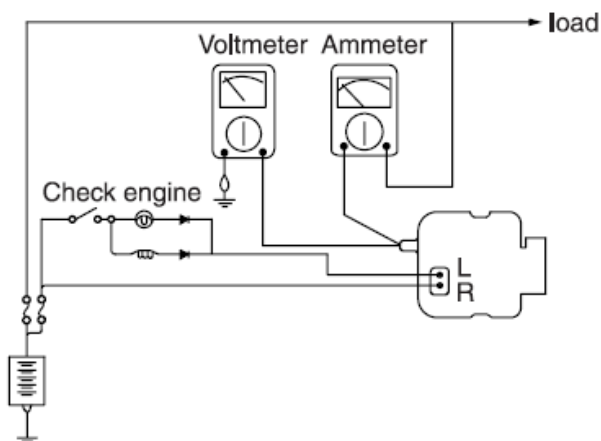

### TEST

1. Check to see that the voltmeter reads as the same value as the battery voltage. If the voltmeter reads 0V, and the open circuit in the wire between alternator "B" terminal and battery (-) terminal or poor grounding is suspected.
2. Start the engine and turn on the headlamps.
3. Set the headlamps to high beam and the heater blower switch to HIGH, quickly increase the engine speed to 2,500 rpm and read the maximum output current value indicated by the ammeter.

### NOTE

*After the engine start up, the charging current quickly drops. Therefore, the above operation must be done quickly to read the maximum current value correctly.*

### RESULT

1. The ammeter reading must be higher than the limit value. If it is lower but the alternator output wire is in good condition, remove the alternator from the vehicle and test it.

**Limit value (70A alternator): 49A min.**

### NOTE

- The nominal output current value is shown on the nameplate affixed to the alternator body.
- The output current value changes with the electrical load and the temperature of the alternator itself. Therefore, the nominal output current may not be obtained. If such is the case, keep the headlamps on the cause discharge of the battery, or use the lights of another vehicle to increase the electrical load.

*The nominal output current may not be obtained if the temperature of the alternator itself or ambient temperature is too high.  
In such a case, reduce the temperature before testing again.*

2. Upon completion of the output current test, lower the engine speed to idle and turn off the ignition switch.
3. Disconnect the battery ground cable.
4. Remove the ammeter and voltmeter and the engine tachometer.
5. Connect the alternator output wire to the alternator "B" terminal.
6. Connect the battery ground cable.

## REGULATED VOLTAGE TEST

The purpose of this test is to check that the electronic voltage regulator controls voltage correctly.

### PREPARATION

1. Prior to the test, check the following items and correct if necessary.  
Check that the battery installed on the vehicle is fully charged. The battery checking method is described in the section "Battery".  
Check the alternator drive belt tension. The belt tension check method is described in the section "Inspect drive belt".
2. Turn ignition switch to "OFF".
3. Disconnect the battery ground cable.
4. Connect a digital voltmeter between the "B" terminal of the alternator and ground. Connect the (+) lead of the voltmeter to the "B" terminal of the alternator. Connect the (-) lead to good ground or the battery (-) terminal.
5. Disconnect the alternator output wire from the alternator "B" terminal.
6. Connect a DC ammeter (0 to 150A) in series between the "B" terminal and the disconnected output wire. Connect the (-) lead wire of the ammeter to the disconnected output wire.
7. Attach the engine tachometer and connect the battery ground cable.

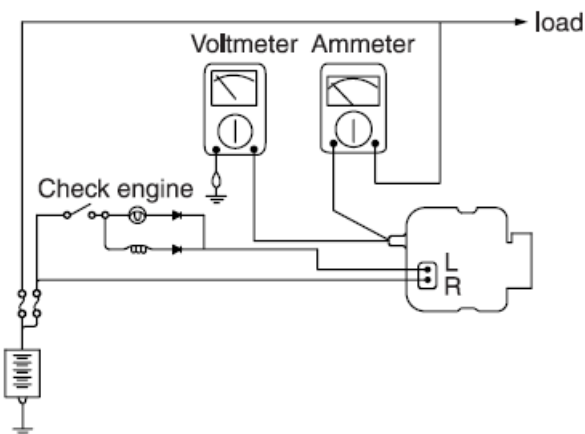

## TEST

1. Turn on the ignition switch and check to see that the voltmeter indicates the following value.

### *Voltage: Battery voltage*

If it reads 0V, there is an open circuit in the wire between the alternator "B" terminal and the battery and the battery (-) terminal.

2. Start the engine. Keep all lights and accessories off.
3. Run the engine at a speed of about 2,500 rpm and read the voltmeter when the alternator output current drops to 10A or less.

## RESULT

1. If the voltmeter reading agrees with the value listed in the regulating voltage table below, the voltage regulator is functioning correctly. If the reading is other than the standard value, the voltage regulator or the alternator is faulty.

### REGULATING VOLTAGE TABLE

Voltage regulator ambient temperature °C (°F)	Regulating voltage (V)
-20 (-4)	14.2 ~ 15.4
20 (68)	14.0 ~ 15.0
60 (140)	13.7 ~ 14.9
80 (176)	13.5 ~ 14.7

2. Upon completion of the test, reduce the engine speed to idle, and turn off the ignition switch.
3. Disconnect the battery ground cable.
4. Remove the voltmeter and ammeter and the engine tachometer.
5. Connect the alternator output wire to the alternator "B" terminal.
6. Connect the battery ground cable.

## GENERATOR

### REPLACEMENT

1. Disconnect the battery negative terminal first, then the positive terminal.
2. Disconnect the alternator connector (A), and remove the cable (B) from the alternator "B" terminal.

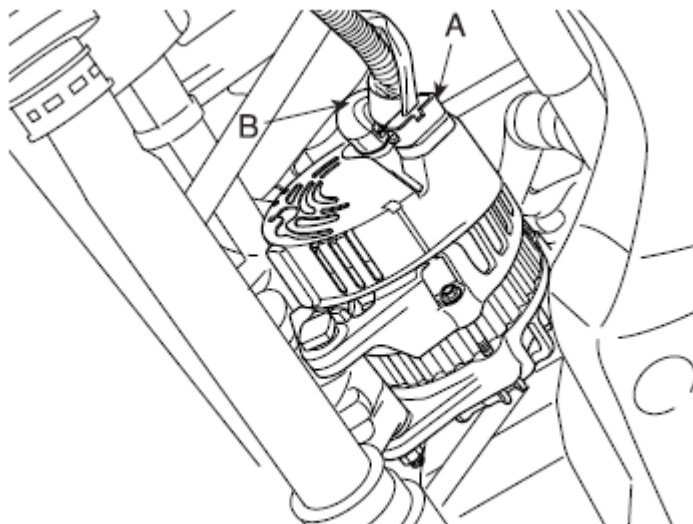

3. Remove the adjusting bolt (A) and mounting bolt (B), then remove the alternator drive belt.
4. Pull out the through bolt (C) and then remove the alternator (D).

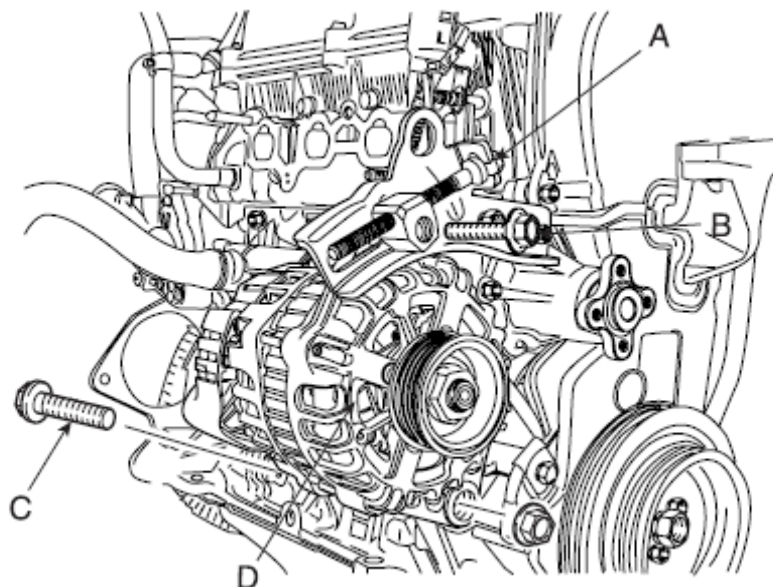

5. Installation is the reverse order of removal.
6. Adjust the alternator belt tension after installation.

## COMPONENT

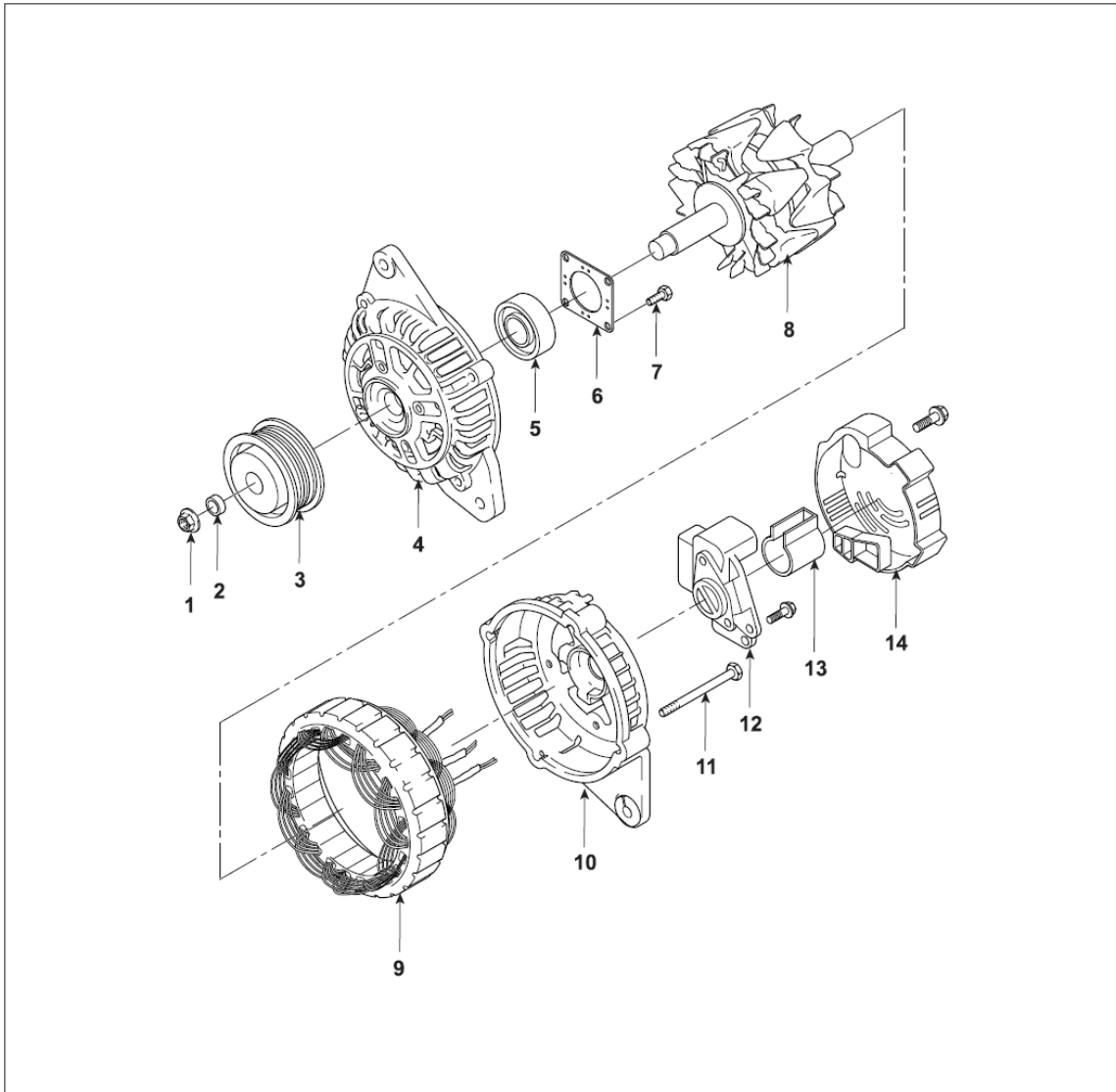

- |                       |                     |
|-----------------------|---------------------|
| 1. Nut                | 8. Rotor            |
| 2. Spacer             | 9. Stator           |
| 3. Pulley             | 10. Rear bracket    |
| 4. Front bracket      | 11. Through bolts   |
| 5. Front bearing      | 12. Regulator       |
| 6. Bearing cover      | 13. Slip ring guide |
| 7. Bearing cover bolt | 14. Rear cover      |



## DISASSEMBLY

1. Remove the 2 bolts (B) and rear cover (A).

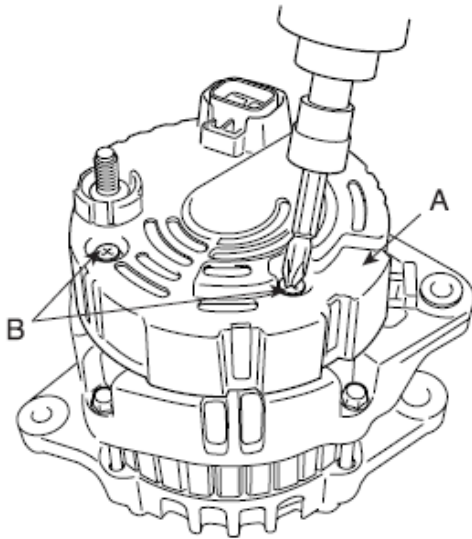

2. Remove the slip ring guide (A) from the regulator.

### NOTE

*When removing the slip ring guide, be careful that other parts are not damaged.*

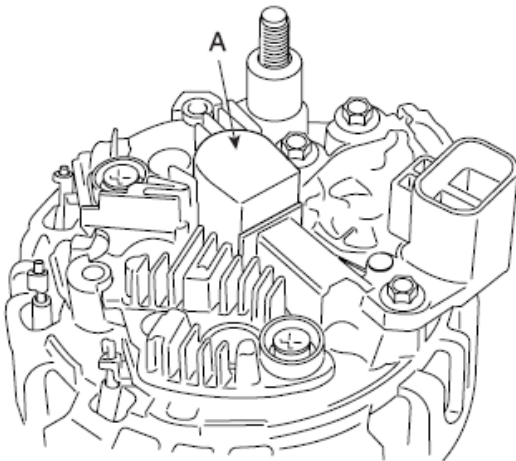

3. Remove the 3 bolts (A) and regulator.

### NOTE

*When removing the regulator, be careful that slip ring is not damaged.*

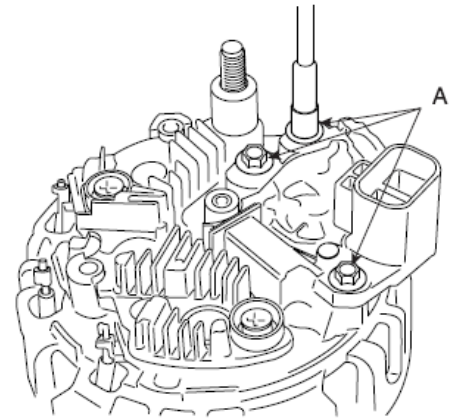

4. Remove the 4 through bolts (A).

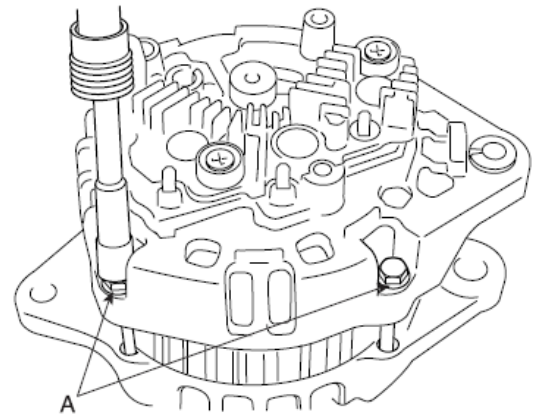

5. Insert a flat screwdriver between the front bracket and stator core, and pry downward.

### NOTE

*Do not insert the screwdriver too deeply, as there is a danger of damaging the stator coil.*

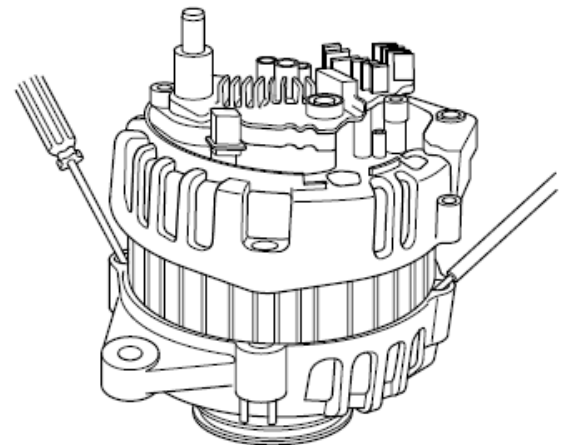

6.Remove the nut and pulley (A).

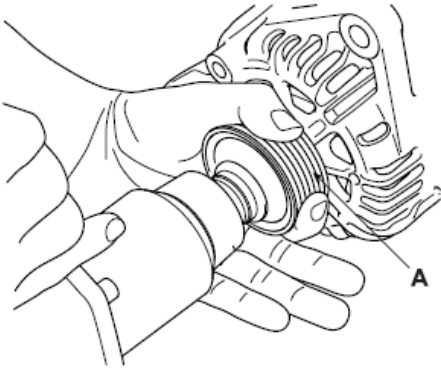

7.Remove the rotor (A) and front bracket (B).

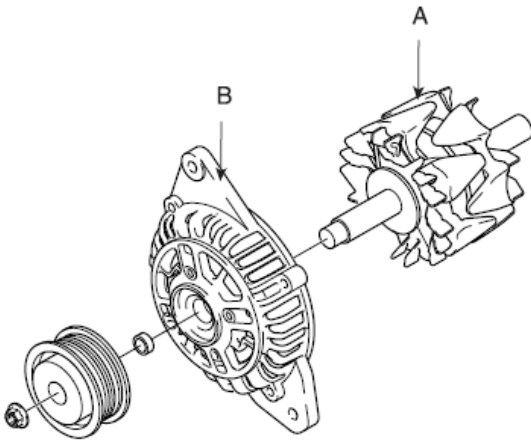

8.Reassembly is the reverse order of disassembly.

## INSPECTION

### INSPECT ROTOR

1.Check that there is continuity between the slip rings (A).

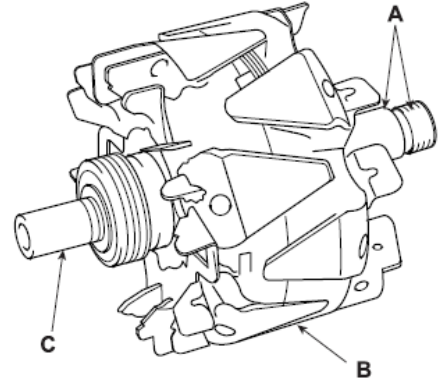

2.Check that there is no continuity between the slip rings and the rotor (B) or rotor shaft (C).

3.If the rotor fails either continuity check, replace the alternator.

### INSPECT STATOR

1.Check that there is continuity between each pair of leads (A).

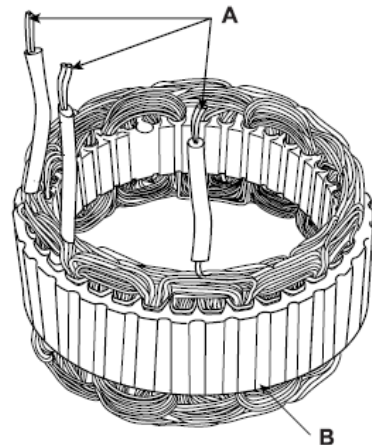

2.Check that there is no continuity between each lead and the coil core.

3.If the coil fails either continuity check, replace the alternator.



## ALTERNATOR BELT INSPECTION AND ADJUSTMENT

### NOTE

When using a new belt, first adjust the deflection or tension to the values for the new belt, then readjust the deflection or tension to the value for the used belt after running engine for five minutes.

### DEFLECTION METHOD:

Apply a force of 98N (10kg, 22lb), and measure the deflection between the alternator and water pump pulley.

---

Deflection

Used belt: 9.5 ~ 11.0mm (0.3740 ~ 0.4331)

New belt: 8.5 ~ 9.5mm (0.3346 ~ 0.3740)

---

### NOTE

If the belt is worn or damaged, replace it.

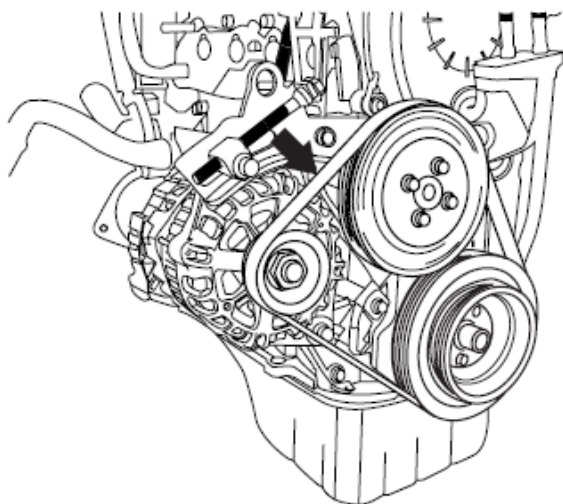

### IF ADJUSTMENT IS NECESSARY:

1. Loosen the adjusting bolt (A) and the lock bolt (B, C).
2. Move the alternator to obtain the proper belt tension, then retighten the nuts.

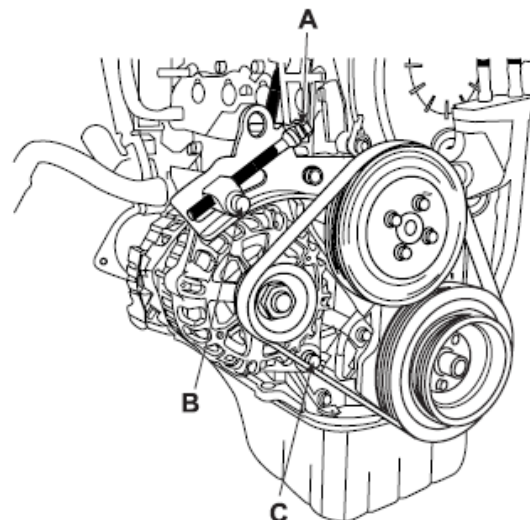

3. Recheck the deflection or tension of the belt.

### NOTE

For the power steering pump belt and A/C compressor belt adjustments, refer to ST group - power steering pump and HA group - air conditioner compressor.

## BATTERY

### DESCRIPTION

Battery water level should be checked regularly.

The water level should be checked frequently if the battery is under heavier loads (i.e. being discharged and recharged more often).

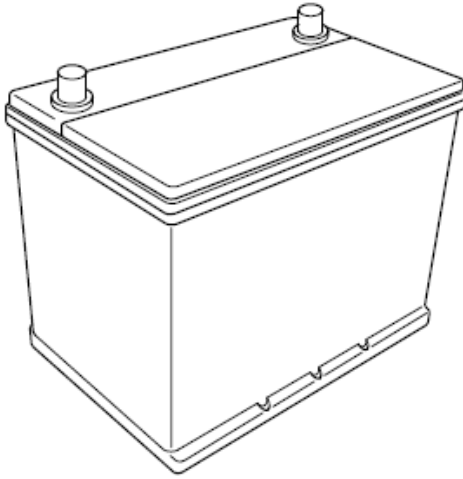

**INSPECTION**

**BATTERY DIAGNOSTIC TEST (1)**

**CHECKING FLOW**

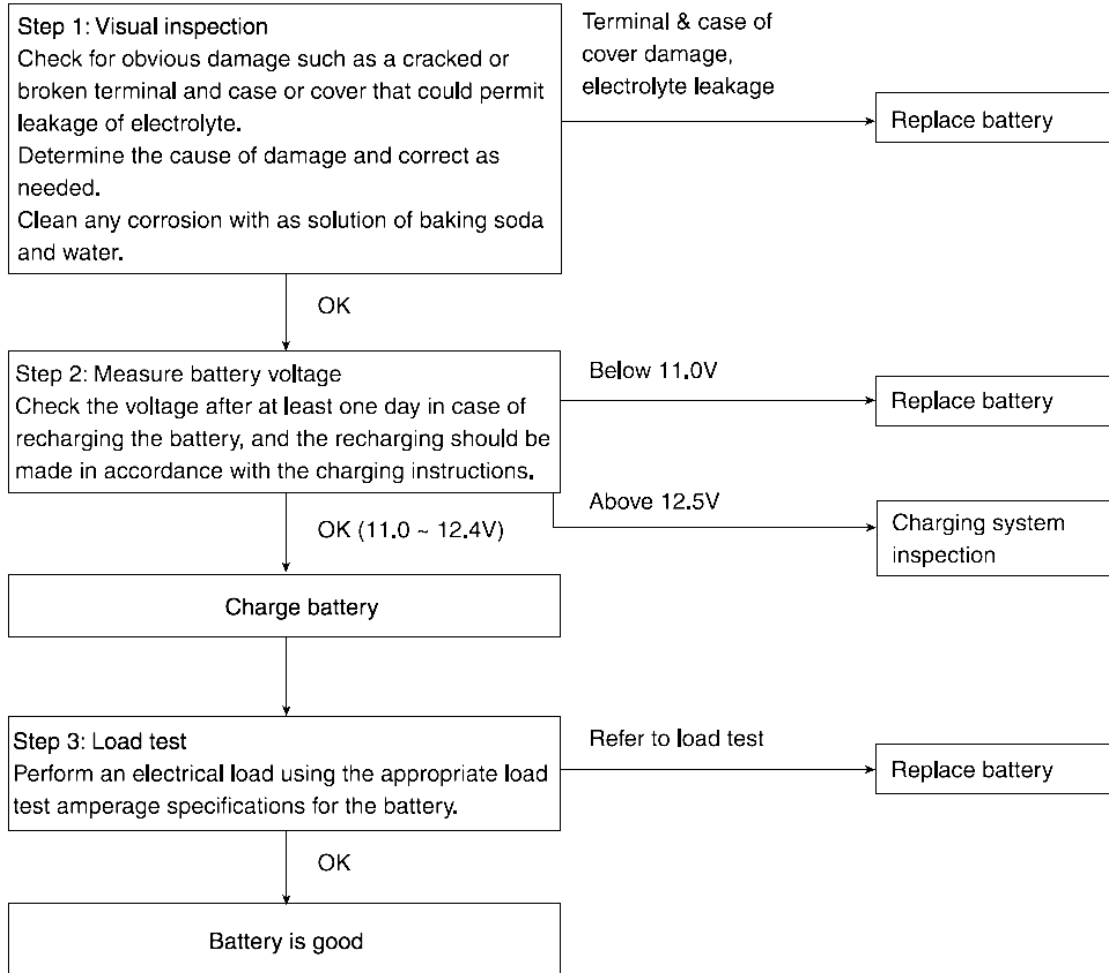

**LOAD TEST**

1. Perform the following steps to complete the load test procedure for maintenance free batteries.
2. Connect the load tester clamps to the terminals and proceed with the test as follow:
  - 1) If the battery has been on charge, remove the surface charge by connect a 300ampere load for 15seconds.
  - 2) Connect the voltmeter and apply the specified load.
  - 3) Read the voltage after the load has been applied for 15 seconds.
  - 4) Disconnect the load.
  - 5) Compare the voltage reading with the minimum and replace the battery if battery test voltage is below that shown in the voltage table.

Voltage	Temperature
9.6V	20°C (68.0 °F) and above
9.5V	16°C (60.8°F)
9.4V	10°C (50.0°F)
9.3V	4°C (39.2°F)
9.1V	-1°C (30.2°F)
8.9V	-7°C (19.4°F)
8.7V	-12°C (10.4°F)
8.5V	-18°C (-0.4°F)

**NOTE**

*If the voltage is greater shown in the table, the battery is good.*

*If the voltage is less than shown in the table, replace the battery.*

**BATTERY DIAGNOSTIC TEST (2)**

1. Make sure the ignition switch and all accessories are in the OFF position.
2. Disconnect the battery cables (negative first).
3. Remove the battery from the vehicle.

**CAUTION**

***Care should be taken in the event the battery case is cracked or leaking, to protect your skin from the electrolyte. Heavy rubber gloves (not the house hold type) should be wore when removing the battery.***

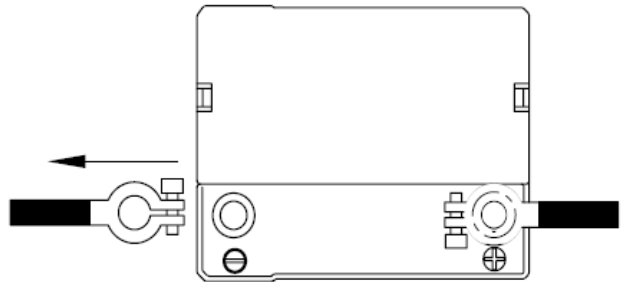

4. Inspect the battery tray for damage caused by the loss of electrolyte. If acid damage is present, it will be necessary to clean the area with a solution of clean warm water and baking soda. Scrub the area with a stiff brush and wipe off with a cloth moistened with baking soda and water.
5. Clean the top of the battery with the same solution as described above.
6. Inspect the battery case and cover for cracks. If cracks are present, the battery must be replaced.
7. Clean the battery posts with a suitable battery post tool.
8. Clean the inside surface of the terminal clamps with a suitable battery cleaning tool. Replace damaged or frayed cables and broken terminal clamps.

9. Install the battery in the vehicle.
10. Connect the cable terminals to the battery post, making sure tops of the terminals are flush with the tops of the posts.
11. Tighten the terminal nuts securely.
12. Coat all connections with light mineral grease after tightening.

**CAUTION**

***When batteries are being charged, an explosive gas form beneath the cover of each cell. Do not smoke near batteries being charged or which have recently been charged. Do not break live circuit at the terminals of batteries being charged. A spark will occur when the circuit is broken. Keep open flames away from battery.***

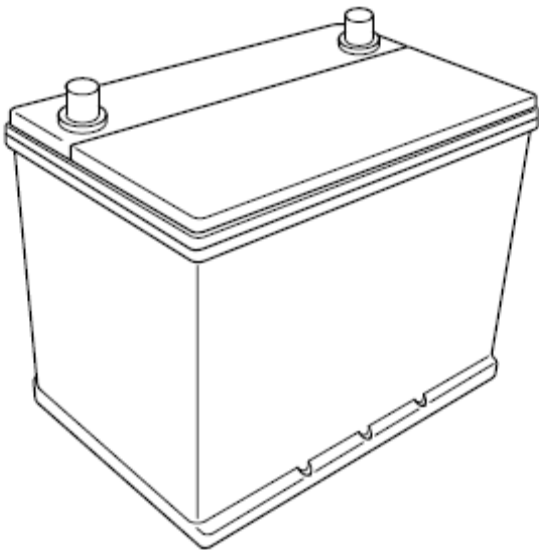

# STARTING SYSTEM

## DESCRIPTION

The starting system includes the battery, starter, solenoid switch, ignition switch, inhibitor switch (A/T), ignition lock switch, connection wires and the battery cable.

When the ignition key is turned to the start position, current flows and energizes the starter motor's solenoid coil.

The solenoid plunger and clutch shift lever are activated, and the clutch pinion engages the ring gear.

The contacts close and the starter motor cranks. In order to prevent damage caused by excessive rotation of the starter armature when the engine starts, the clutch pinion gear overruns.

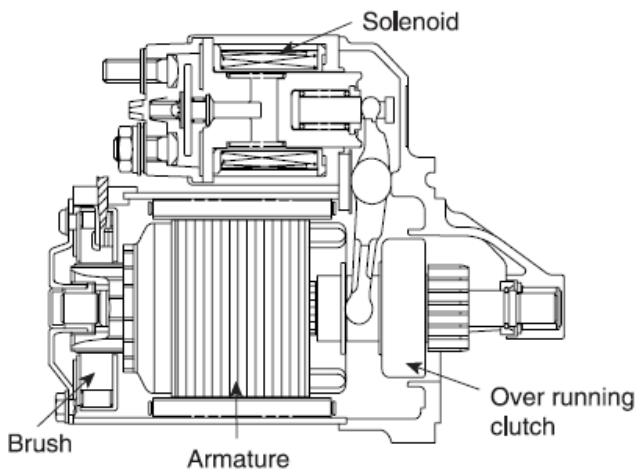

## STARTER CIRCUIT TROUBLESHOOTING

### NOTE

*The battery must be in good condition and fully charged.*

1. Remove the fuel pump relay (A) from the fuse box.

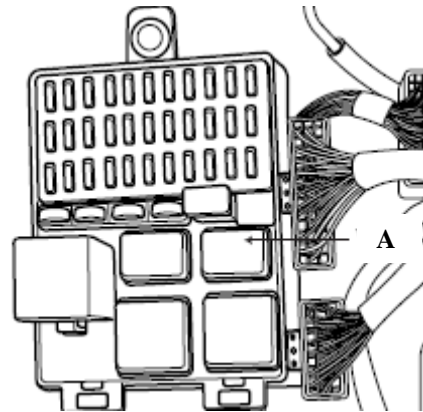

2. With the shift lever in N or P (A/T) or clutch pedal pressed (M/T), turn the ignition switch to START.

If the starter cranks the engine normally, starting system is OK. If the starter will not crank the engine at all, go to next step.

If it won't disengage from the ring gear when you release key, check for the following until you find the cause.

- Solenoid plunger and switch malfunction.
- Dirty pinion gear or damaged overrunning clutch.

3. Check the battery condition. Check electrical connections at the battery, battery negative cable connected to the body, engine ground cables, and the starter for looseness and corrosion. Then try starting the engine again.

If the starter cranks the engine normally, repairing the loose connection repaired the problem. The starting system is now OK.

If the starter still does not crank the engine, go to next step.

4. Disconnect the connector from the S-terminal of solenoid. Connect a jump wire from the B-terminal of solenoid to the S-terminal of solenoid.

If the starter cranks the engine, go to next step.  
If the starter still does not crank the engine, remove the starter, and repair or replace as necessary.

5. Check the following items in the order listed until you find the open circuit.
- Check the wire and connectors between the driver's under-dash fuse/relay box and the ignition switch, and between the driver's under-dash fuse/relay box and the starter.
  - Check the ignition switch (Refer to BE group ignition system)
  - Check the transaxle range switch connector or ignition lock switch connector.
  - Inspect the starter relay.

### STATER SOLENOID TEST

1. Disconnect the field coil wire from the M-terminal of solenoid switch.
2. Connect a 12V battery between S-terminal and the starter body.

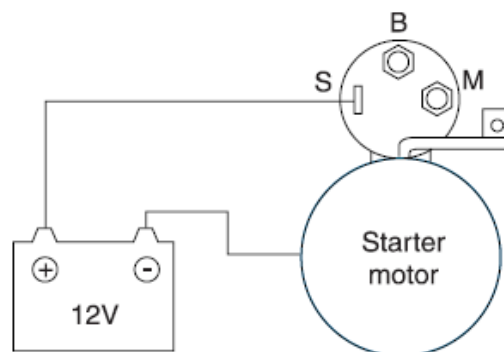

3. Connect the field coil wire to the M-terminal.

### CAUTION

***This test must be performed quickly (in less than 10 seconds) to prevent the coil from burning.***

4. If the pinion moves out, the pull-in coil of solenoid is working properly.  
If the pinion does not move, replace the solenoid.
5. Disconnect the field coil wire from the M-terminal.
6. If the pinion has moved out, the hold-in coil of the solenoid is working properly.  
If the pinion moves in, replace the solenoid.

**FREE RUNNING TEST**

1. Place the starter motor in a vise equipped with soft jaws and connect a fully-charged 12-volt battery to starter motor as follows:
2. Connect a test ammeter (100-ampere scale) and carbon pile rheostats shown in the illustration.
3. Connect a voltmeter (15-volt scale) across starter motor.

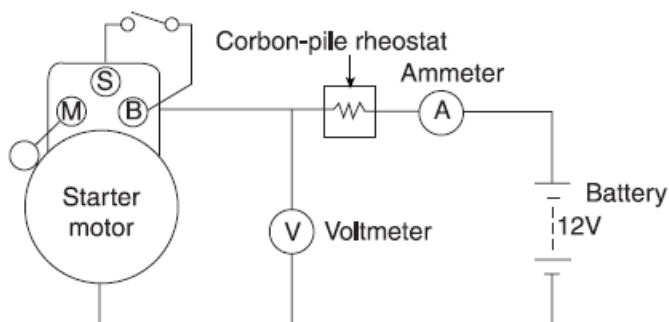

4. Rotate carbon pile to the off position.
5. Connect the battery cable from battery's negative post to the starter motor body.
6. Adjust until battery voltage shown on the voltmeter reads 11volts.
7. Confirm that the maximum amperage is within the specifications and that the starter motor turns smoothly and freely.

---

Current: 60A MAX

Speed: 5500 RPM

---

**STARTER****REPLACEMENT**

1. Disconnect the battery negative cable.
2. Disconnect the connector (A) from the S terminal, and remove the cable (B) from the B terminal.

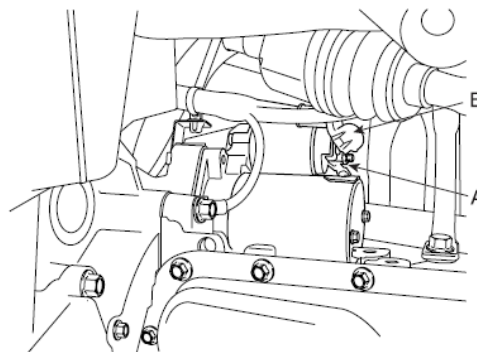

3. Remove the 2 bolts holding the starter, and then remove the starter.

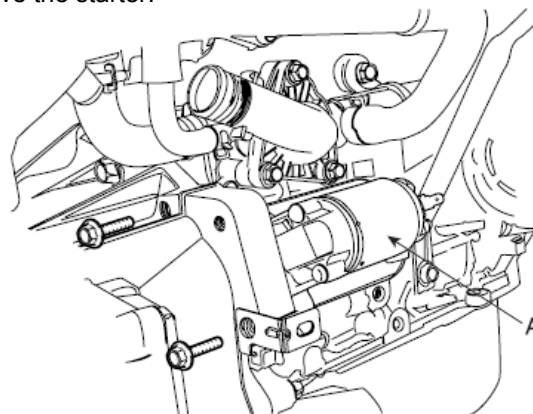

4. Installation is the reverse of removal.
5. Connect the battery negative cable to the battery.



## COMPONENT

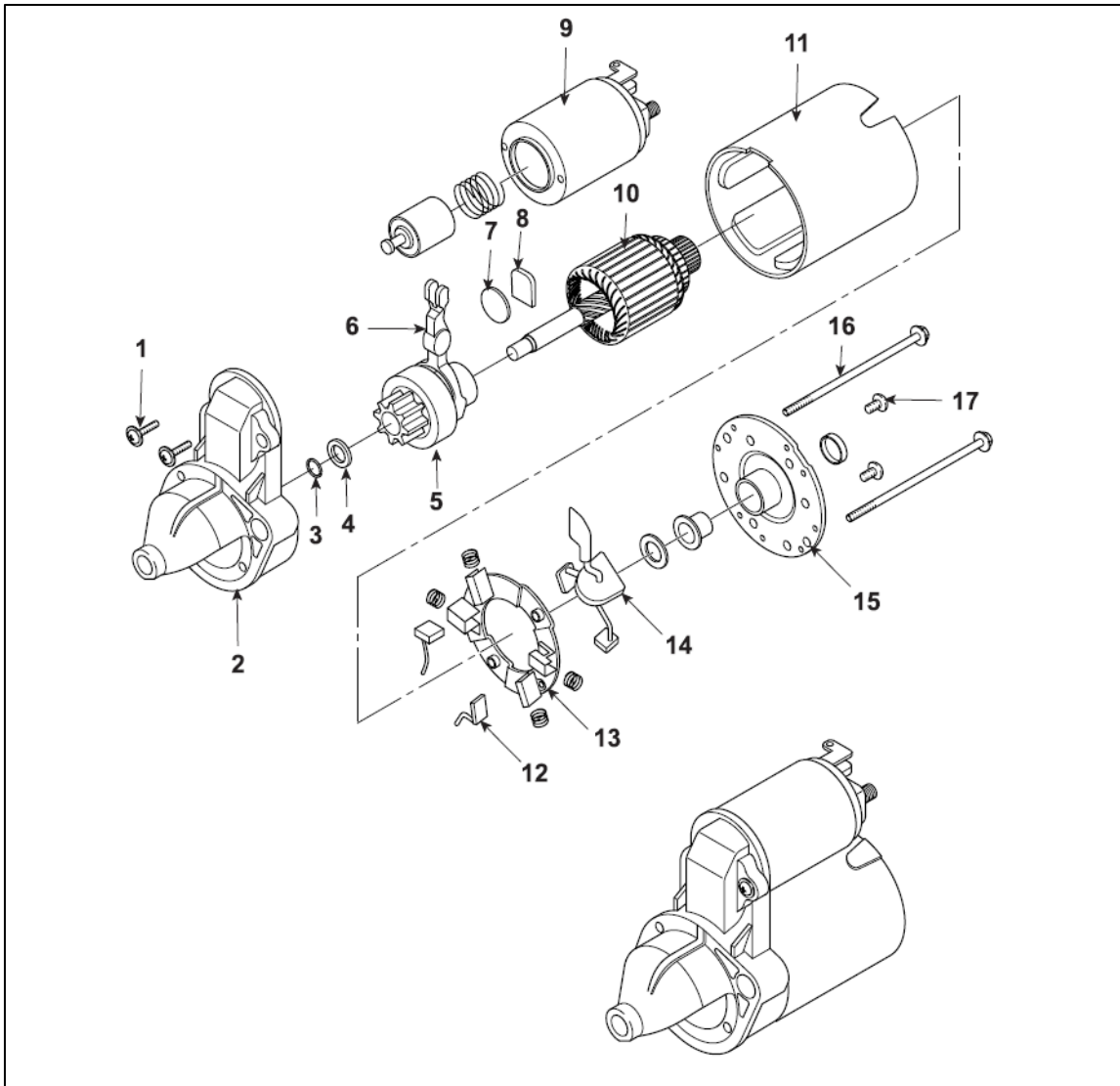

- |                           |                           |
|---------------------------|---------------------------|
| 1. Screw                  | 10. Armature assembly     |
| 2. Front bracket assembly | 11. Yoke assembly         |
| 3. Stop ring              | 12. Brush ( - )           |
| 4. Stopper                | 13. Brush holder assembly |
| 5. Overrunning clutch     | 14. Brush ( + )           |
| 6. Lever                  | 15. Rear bracket          |
| 7. Plate                  | 16. Through bolt          |
| 8. Lever packing          | 17. Screw                 |
| 9. Magnet switch assembly |                           |

**DISASSEMBLY**

1. Disconnect the M-terminal (A) on the magnet switch assembly (B).

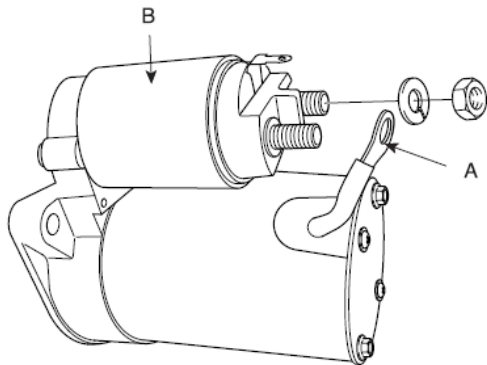

2. After loosening the 2 screws (A), detach the magnet switch assembly (B).

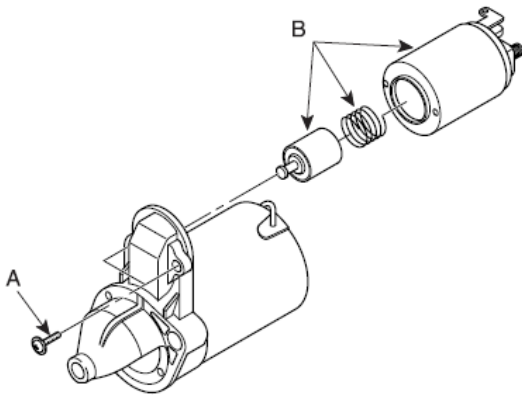

3. Loosen the brush holder mounting screw (A) and through bolts (B).

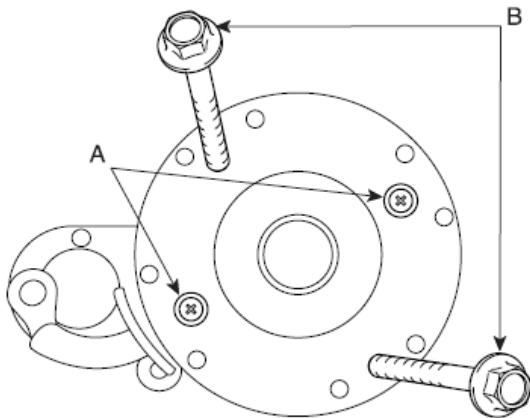

4. Remove the rear bracket (A) and brush holder assembly (B).

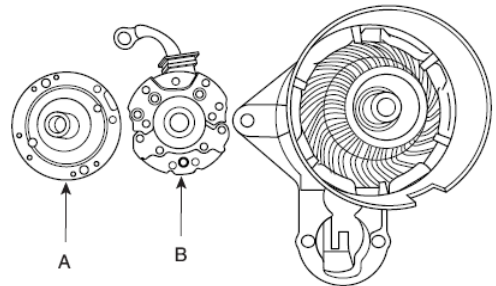

5. Remove the yoke (A) and armature (B).

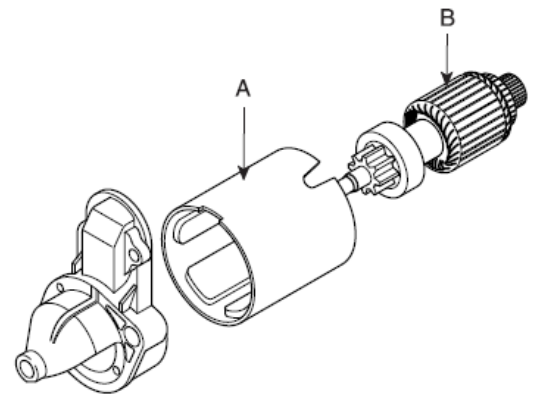

6. Remove the lever plate (A) and packing (B).

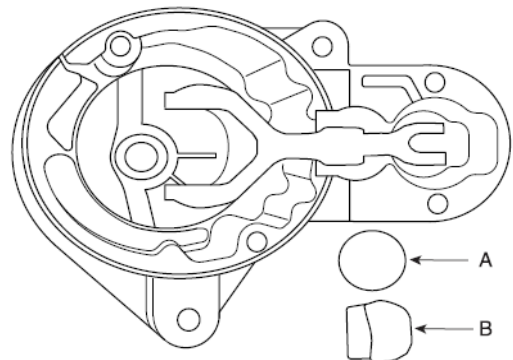

7. Remove the overrunning clutch (A) and lever (B).

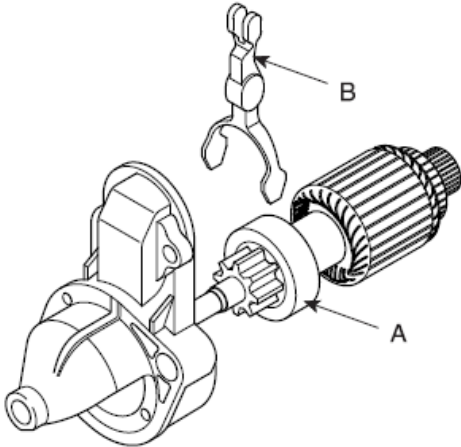

8. Press the stop ring (A) using a socket (B).

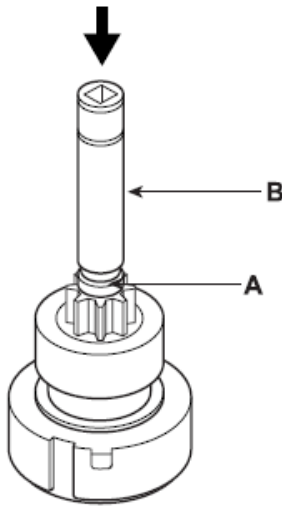

9. After removing the stopper (A) using stopper pliers (B).

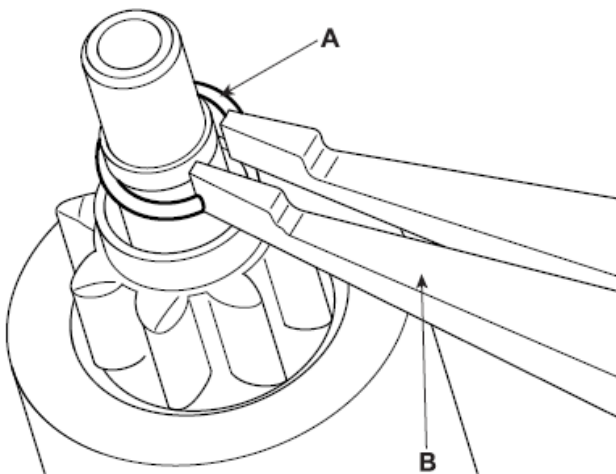

10. Remove the stopper (A), stop ring (B), overrunning clutch (C) and armature (D).

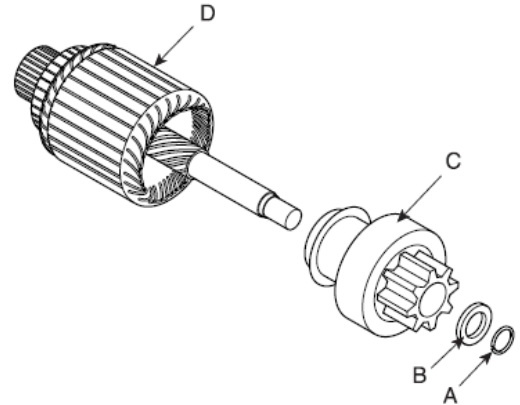

11. Reassembly is the reverse of disassembly.

**NOTE**

Using a suitable pulling tool (A), pull the overrunning clutch stop ring (B) over the stopper (C).

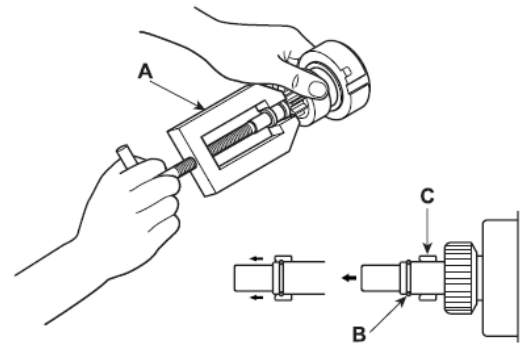

## INSPECTION

### ARMATURE INSPECTION AND TEST

1. Remove the starter.
2. Disassemble the starter as shown at the beginning of this procedure.
3. Inspect the armature for wear or damage from contact with the permanent magnet. If there is wear or damage, replace the armature.

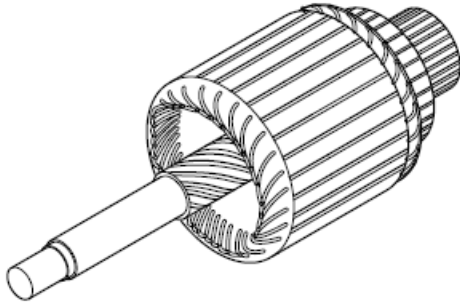

4. Check the commutator (A) surface. If the surface is dirty or burnt, resurface with emery cloth or a lathe within the following specifications, or recondition with #500 or #600 sandpaper (B).

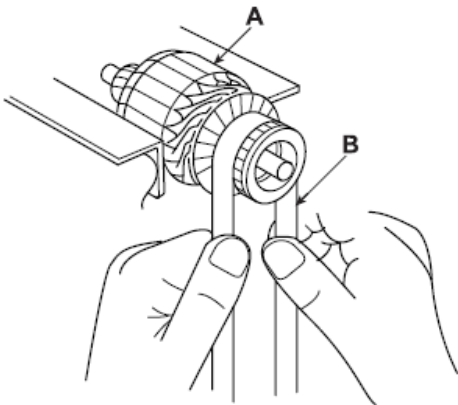

5. Check the commutator diameter. If the diameter is below the service limit, replace the armature.

---

Commutator diameter

Standard (New) : 33.0mm (1.2992in.)

Service limit : 32.4mm (1.2756in.)

---

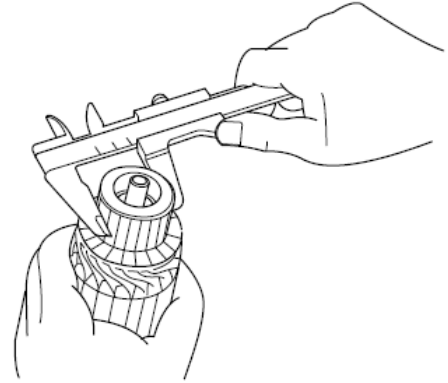

6. Measure the commutator (A) runout.
  - If the commutator runout is within the service limit, check the commutator for carbon dust or brass chips between the segments.
  - If the commutator run out is not within the service limit, replace the armature.

---

Commutator runout

Standard (New): 0.02mm (0.0008in.), max

Service limit: 0.05mm (0.002in.)

---

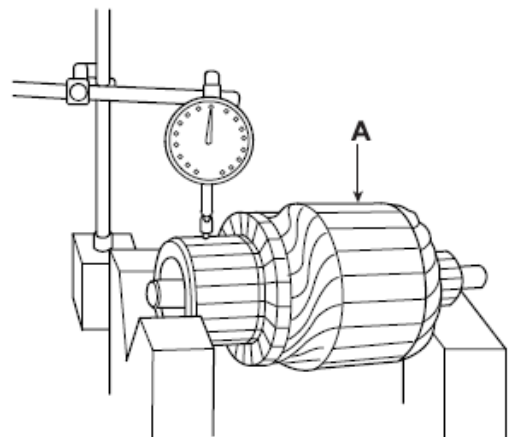

7. Check the mica depth (A). If the mica is too high (B), undercut the mica with a hacksaw blade to the proper depth. Cut away all the mica (C) between the commutator segments. The undercut should not be too shallow, too narrow, or v-shaped (D).

---

Commutator mica depth

Standard (New) : 0.5mm (0.0197in.)

Limit : 0.2mm (0.0079in.)

---

8. Check for continuity between the segments of the commutator. If an open circuit exists between any segments, replace the armature.

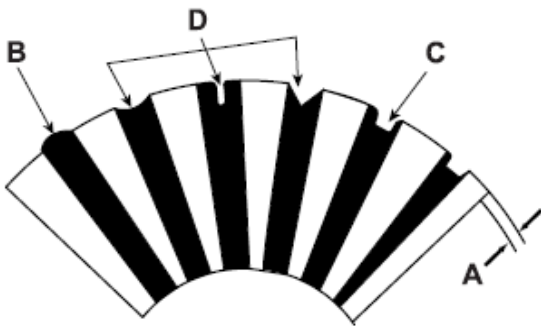

9. Check with an ohmmeter that no continuity exists between the commutator (A) and armature coil core (B), and between the commutator and armature shaft (C). If continuity exists, replace the armature.

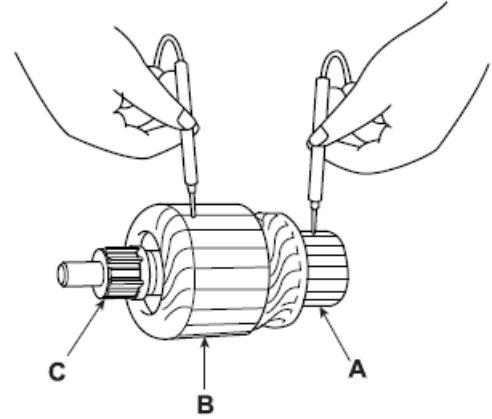

### INSPECT STARTER BRUSH

Brushes that are worn out, or oil-soaked, should be replaced.

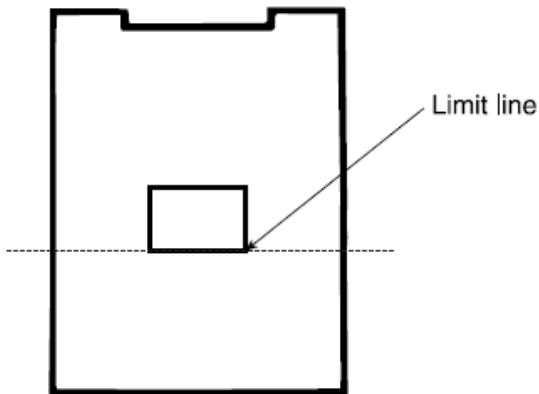

#### NOTE

The seat new brushes, slip a strip of #500 or #600 sandpaper, with the grit side up, between the commutator and each brush, and smoothly rotate the armature. The contact surface of the brushes will be sanded to the same contour as the commutator.

### STARTER BRUSH HOLDER TEST

1. Check that there is no continuity between the (+) brush holder (A) and (-) brush holder (B). If there is no continuity, replace the brush holder assembly.

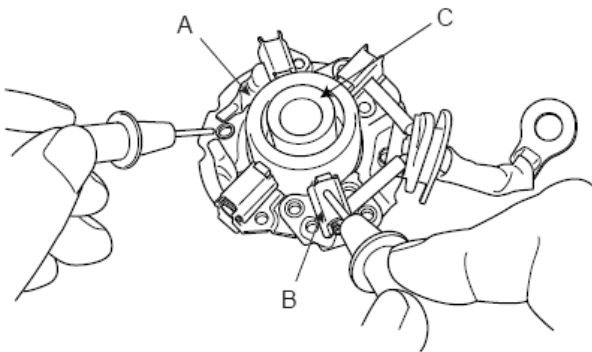

#### NOTE

Use a pipe (C) of suitable size for the brushes not to get removed from the brush holder.

### INSPECT OVERRUNNING CLUTCH

1. Slide the overrunning clutch along the shaft. Replace it if does not slide smoothly.
2. Rotate the overrunning clutch both ways. Does it lock in one direction and rotate smoothly in reverse? If it does not lock in either direction or it locks in both directions, replace it.

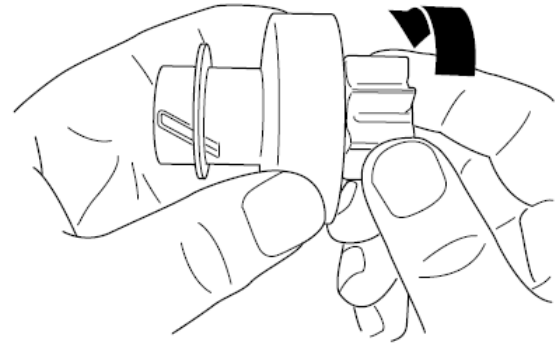

3. If the starter drive gear is worn or damaged, replace the overrunning clutch assembly. (the gear is not available separately)  
Check the condition of the flywheel or torque converter ring gear if the starter drive gear teeth are damaged.

### CLEANING

1. Do not immerse parts in cleaning solvent. Immersing the yoke assembly and/or armature will damage the insulation. Wipe these parts with a cloth only.
2. Do not immerse the drive unit in cleaning solvent. The over running clutch is pre-lubricated at the factory and solvent will wash lubrication from the clutch.
3. The drive unit may be cleaned with a brush moistened with cleaning solvent and wiped dry with a cloth.

## STARTER RELAY

### INSPECTION

1. Remove the fuse box cover.
2. Remove the starter relay (A).

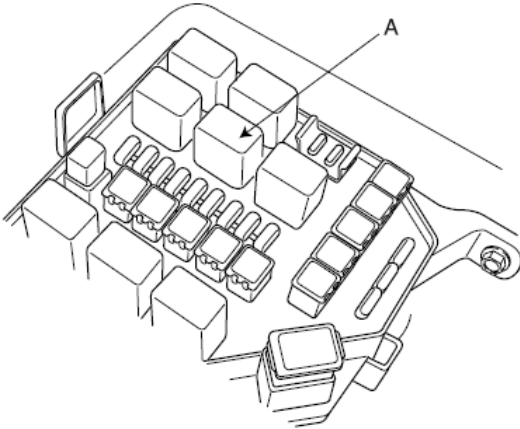

3. Using an ohmmeter, check that there is continuity between each terminal.

Terminal	Continuity
30 - 87	NO
85 - 86	YES

4. Apply 12V to terminal 85 and ground to terminal 86. Check for continuity between terminal 30 and 87.

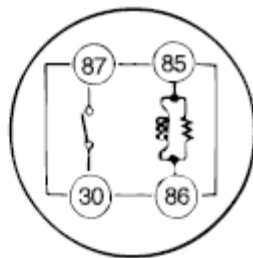
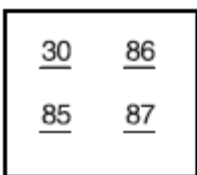

5. If there is no continuity, replace the starter relay.
6. Install the starter relay.
7. Install the fuse box cover.